

WARNING - WARNING - WARNING - WARNING - WARNING - WARNING - WARNING - WARNING - WARNING - WARNING - WARNING - WARNING

The project described on these pages uses **POTENTIALLY FATAL HIGH VOLTAGES**. If you are in any way unfamiliar with high voltage circuitry and the safety precautions critical to working around high voltages, **PLEASE DO NOT RISK YOUR LIFE BY BUILDING THIS PROJECT**. Seek help from a competent electronics technician before building any unfamiliar electronic circuits. Efforts are made to ensure the accuracy of this projects documentation, however, no guarantee is provided, of any kind.

USE OF THIS PROJECT IS AT YOUR OWN RISK: The webmaster, project coordinator, project contributors, and web space provider expressly disclaim all liability for injury or property damage resulting from this information. All information is provided 'AS-IS' and without warranty of any kind.

COPYRIGHT AND INTELLECTUAL PROPERTY NOTICE:

The content of this document is protected by the copyright laws of the United States of America and the international copyright laws and agreements.

No part of this document may be reproduced, displayed, copied, translated, adapted, downloaded, broadcast, used, or republished in any form including, but not limited to, distribution or storage in a system for retrieval without the expressed written permission of Michael Gorsich, DBA **CopperAmps**.

WARNING - WARNING - WARNING - WARNING - WARNING - WARNING - WARNING - WARNING - WARNING - WARNING - WARNING - WARNING

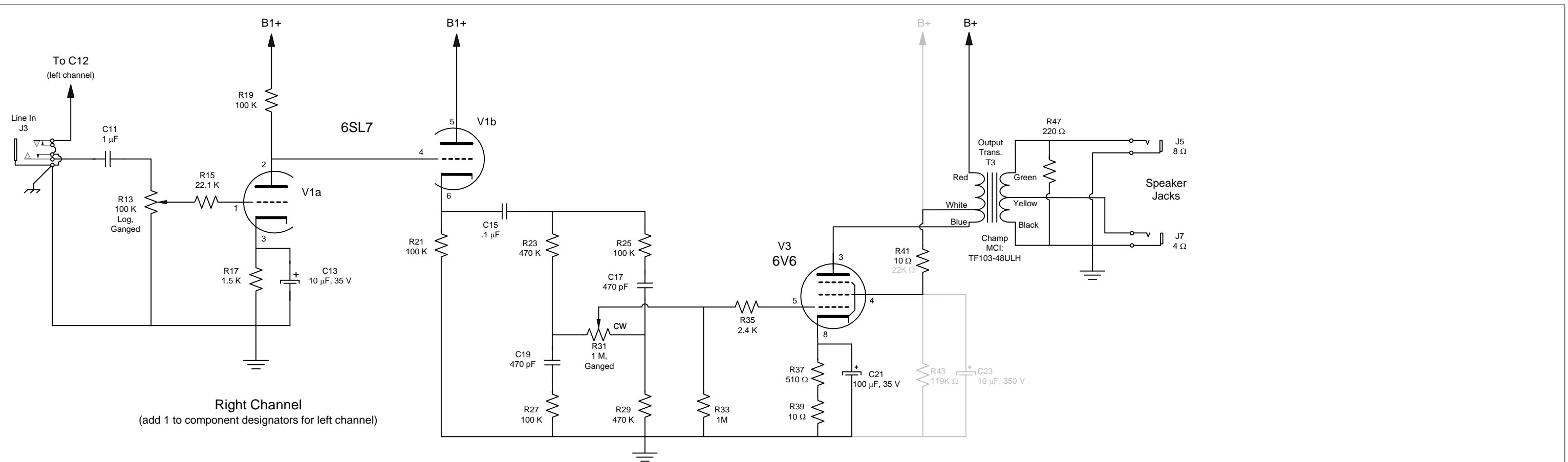

Right Channel
(add 1 to component designators for left channel)

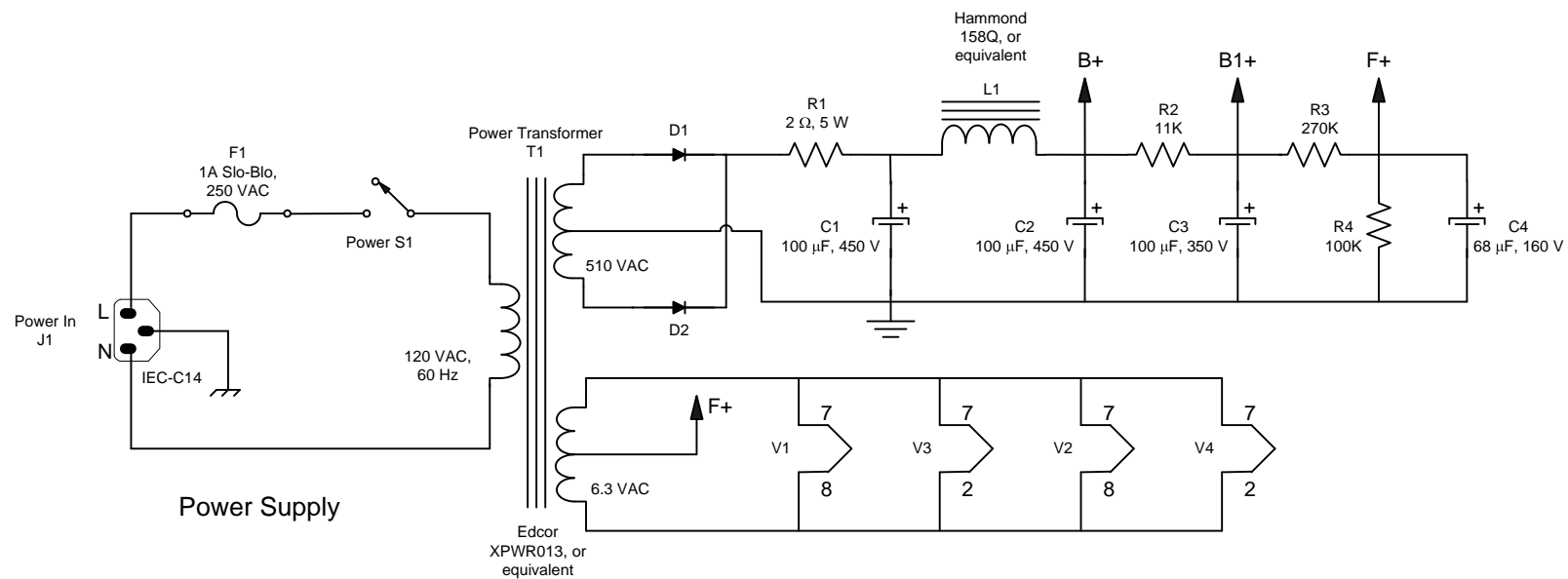

Notes:

1. Power supply component designators: 1 through 10
2. Right channel (shown) component designators begin with 11, odd numbers only. Left channel (not shown) designators begin with 12, even numbers only.
3. Amplifier is shown wired for UL (Ultra-linear) operation. C23, R43, and **grey jumpers** (screen supply) are **not** used with UL operation. If not using UL mode, use grey value for R41 and leave UL tap disconnected (if present).
4. "cw" post is 0 ohms to center post when pot. is fully clockwise.

Project: "Harmless" Stereo Amplifier			
Schematic		Author: Michael Gorsich	
Sheet 2	of 6	Rev. 0	20100426

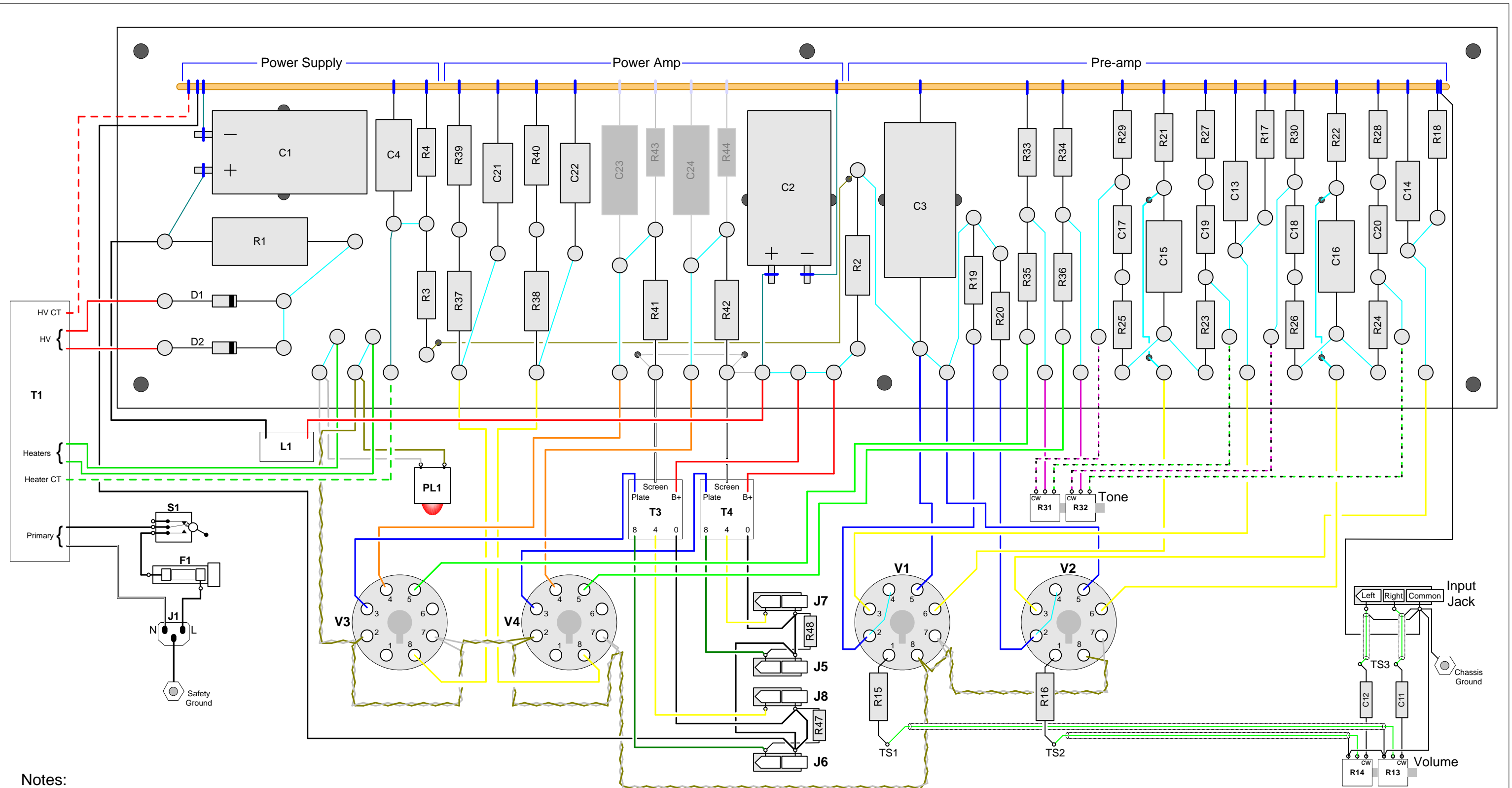

Notes:

1. Circuit board is to scale; remainder is not to scale.
2. C23/24, R43/44, and **grey jumpers** (screen supply) are **not** used with UL (Ultra-linear) operation. See options' notes for R41/42 values when UL mode is not used.
3. "cw" post is 0 ohms to center post when pot. is fully clockwise.
4. Transformer and choke wire colors may vary from shown.
5. Light -cyan jumpers are solid; dark-cyan jumpers are stranded hookup wire.
6. Mounting holes are bored for #8 screws. Tie-wrap filter caps using holes provided.

Project: "Harmless" Stereo Amplifier			
Layout		Author: Michael Gorsich	
Sheet	3	of	6
Rev.	0	20100422	

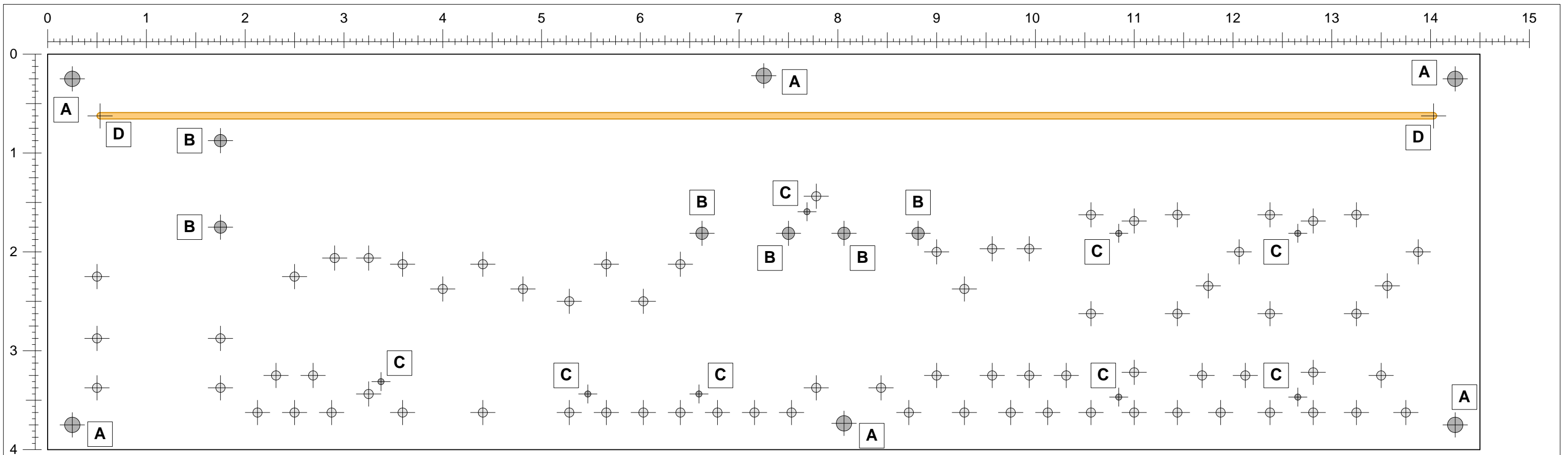

- A** 11/64" mounting holes for #8 screws & standoffs.
- B** 1/8" component mounting holes; sized for small Tie-Wraps.
- C** 5/64" wire pass-through holes; sized for Belden 83006 22 gauge hookup wire.
- ⊕ Bore to 3/32" for Keystone type 1514 turrets; bore with #33 bit for Keystone type 1503 turrets.
- D** 5/64" ground bus mounting hole; sized for 12 gauge bare copper wire interference fit. Bore out to match mounting method.

Notes:

1. Template is to scale. When printing locally, verify print scale percentage and adjust as needed.

Change History:

20090414 Moved location of right ground bus hole 1/16" right for clearance with R18.

Project: "Harmless" Stereo Amplifier

Circuit Board Template	Author: Michael Gorsich
Sheet 4 of 6	Rev. 0 20100414



Rear Edge of Chassis

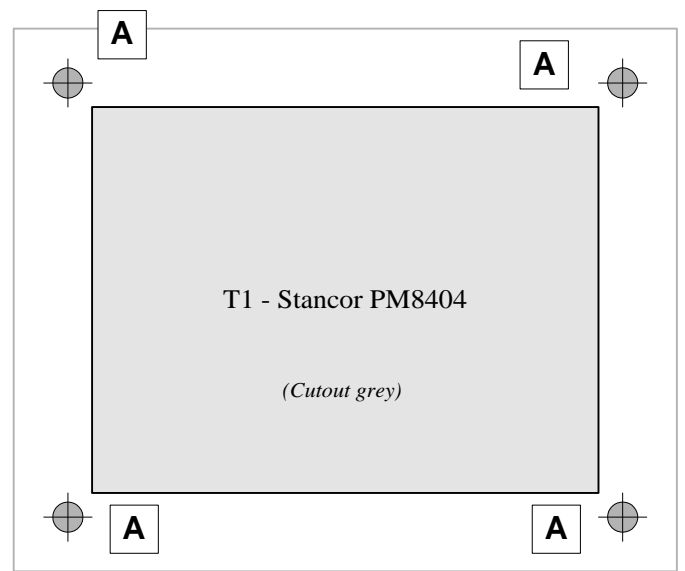
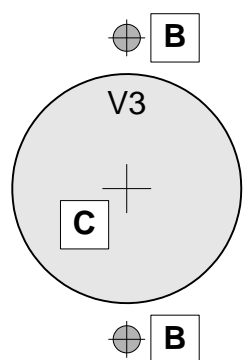
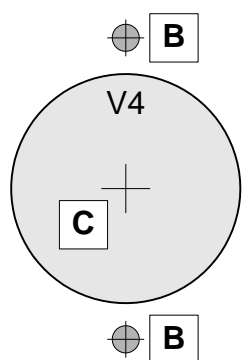
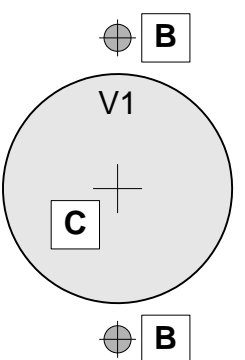
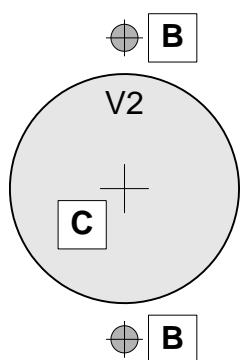
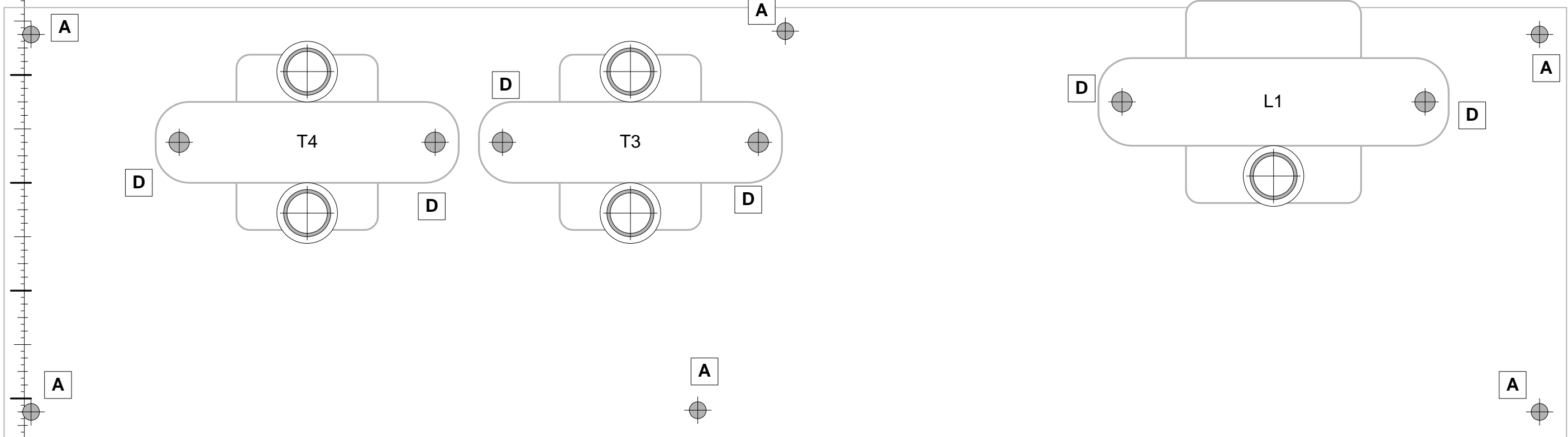

Front Edge of Chassis

- A** 11/64" holes for mounting circuit board. Circuit board mounted with #8 x 1-1/2 screws & standoffs.
- B** 9/64" component mounting hole; sized for #6 screw.
- C** 1-3/16" diameter hole, sized for Belton Micalex octal tube socket
- D** 13/64" component mounting hole; sized for #10 screw.

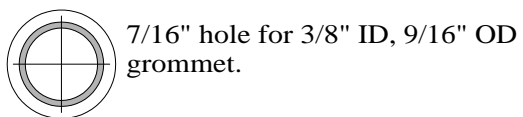

Notes:

1. Template is to scale. When printing locally, verify print scale percentage and adjust as needed. Align left of printed template with left edge of chassis.
2. Chassis and paper are both 17" wide. Part of the template will be outside of the print area. Align paper left edge with chassis left edge. Ensure printer did not clip area of template containing drill marks.

Project: "Harmless" Stereo Amplifier			
Chassis Cutout Plan, Top View		Author: Michael Gorsich	
Sheet	5	of	6
Rev. 0		20100417	

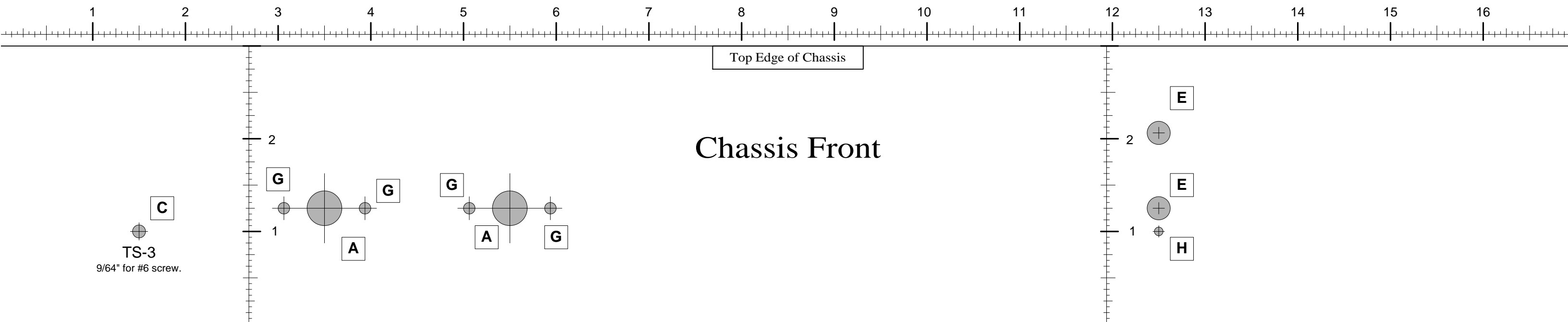

C
TS-3
9/64" for #6 screw.

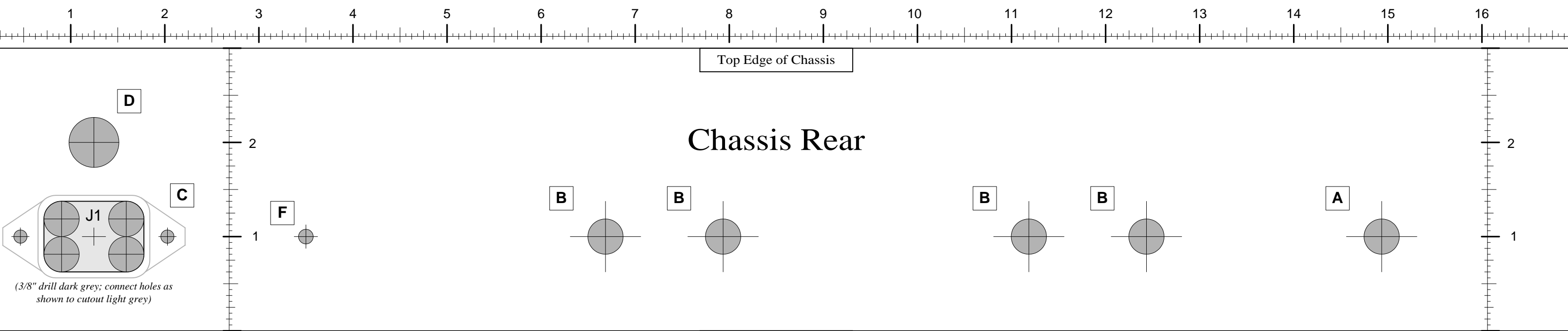

D

C

J1

(3/8" drill dark grey; connect holes as shown to cutout light grey)

- A** 23/64" hole for mounting Switchcraft 1/4" jack, volume, and tone controls. If tight or 23/64" bit is not available, use 3/8".
- B** 27/64" hole for mounting Cliffs insulated 1/4" jack; if tight or 27/64" bit is not available, use 7/16".
- C** IEC-C14 connector cutout. Corners are 3/16" radius. Mounting holes are 9/64" for #6 screw.
- D** 17/32" hole for mounting fuse holder.
- E** 1/4" component mounting hole
- F** 11/64" holes for safety ground connection. Attach ground wire of IEC connector directly to chassis here. Secure with #8 x 1/2 screw, washer, lockwasher & nut.
- G** 1/8" torque-taker holes for potentiometers.
- H** 3/32" alignment hole for power switch.

Notes:

1. Template is to scale. When printing locally, verify print scale percentage and adjust as needed.
2. Chassis and paper are both 17" wide. Part of the template will be outside of the print area. Align paper left edge with chassis left edge. Ensure printer did not clip area of template containing drill marks.

Project: "Harmless" Stereo Amplifier			
Chassis Cutout Plan, Top View		Author: Michael Gorsich	
Sheet	6	of	6
Rev. 0		20100418	